

# REDE ANTIPÁSSAROS E ANTI-INSETOS



## CARACTERÍSTICAS DO PRODUTO

Na indústria alimentar e de distribuição alimentar existe a necessidade de ventilação natural através da cobertura sem a intrusão de animais (insetos, aves).

De forma a precaver para este tipo de situações, respeitando as normas de higiene e segurança, os nossos produtos oferecem dois tipos de soluções: rede anti-pássaro e rede anti-insetos.

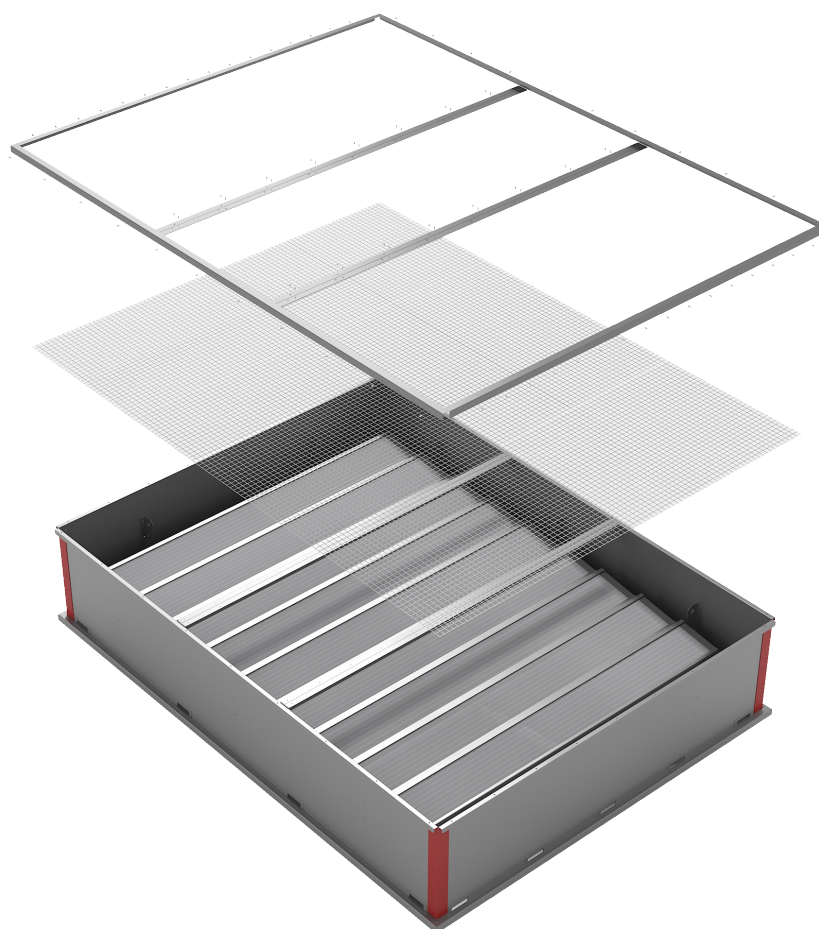

# rede antipássaros e anti-insetos

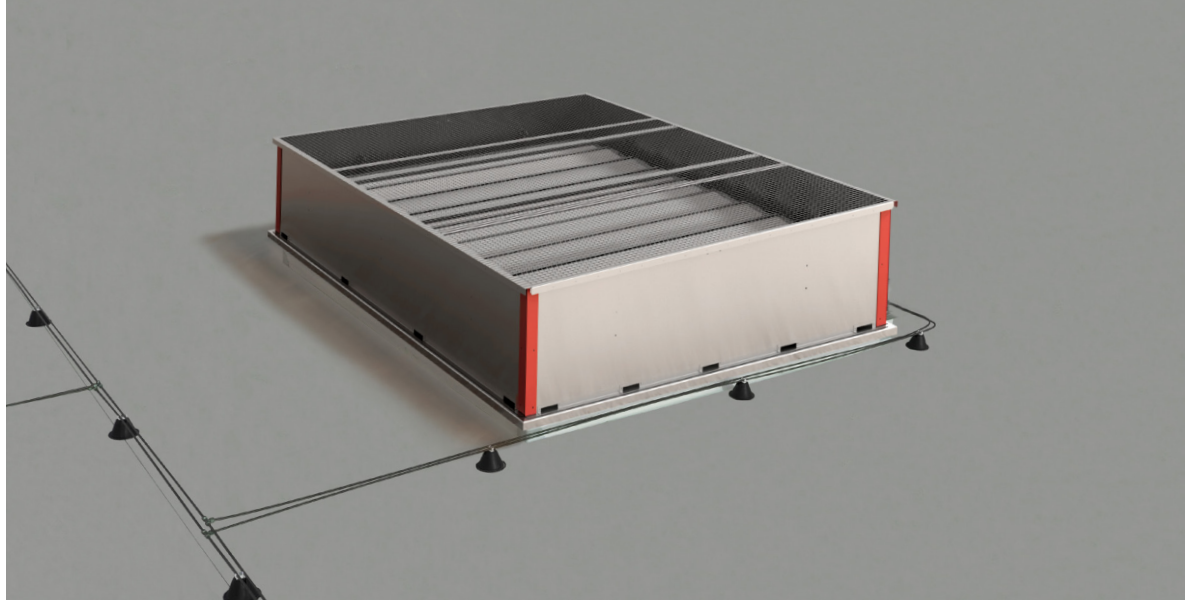

## REDE ANTIPÁSSAROS

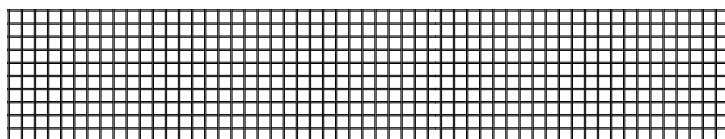

**MALHA 20 X 20 mm**

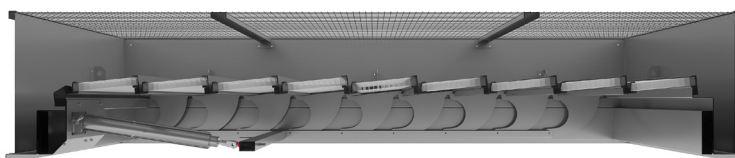

### SECÇÃO S2

**Especificações do produto:** rede soldada em aço galvanizado Ø2 mm e malha de 20x20 mm. Aplicado no topo da abertura do exutor.

## REDE ANTI-INSETOS

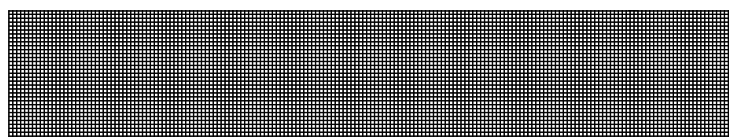

**1,1 X 1,35 mm MALHA**

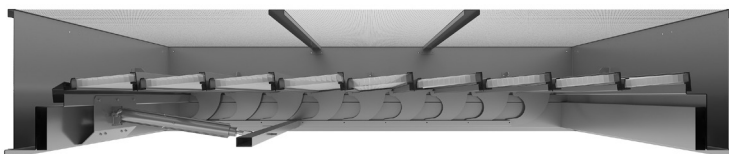

### SECÇÃO S2

**Especificações do produto:** rede em alumínio. Aplicado no topo da abertura do exutor.

## REDE ANTIPÁSSAROS

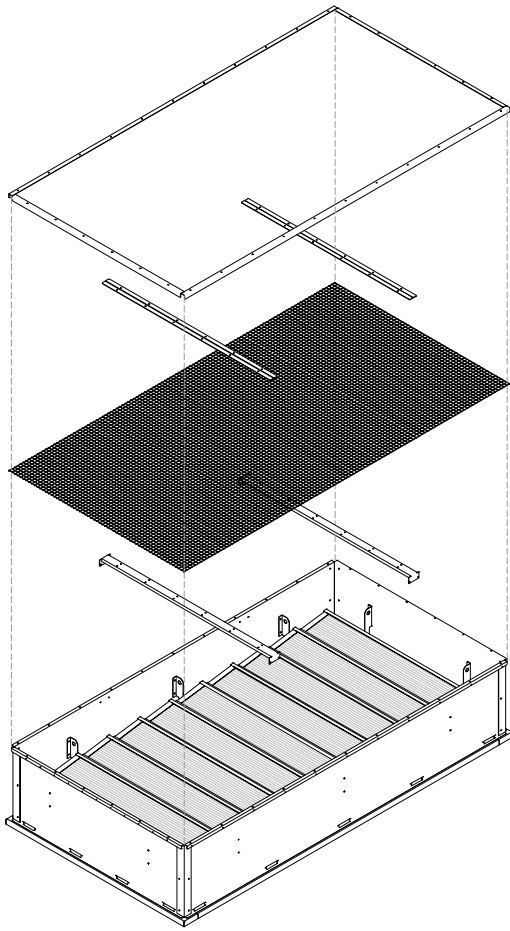

ESQUEMA DE MONTAGEM

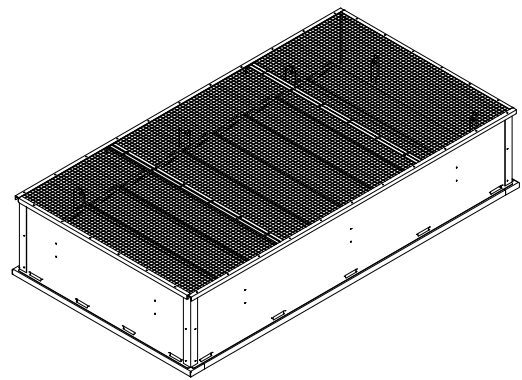

VISTA EM PERSPETIVA

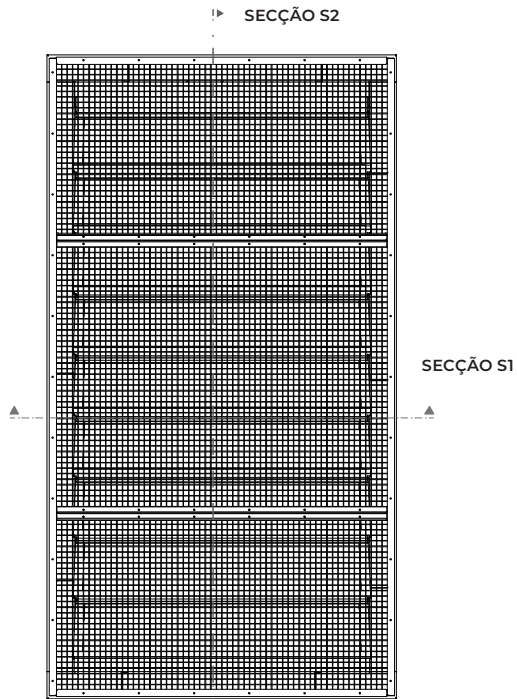

VISTA DE TOPO

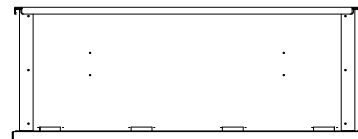

VISTA FRONTAL

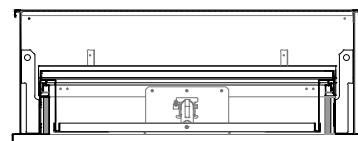

SECÇÃO S1

# REDE ANTI-INSETOS

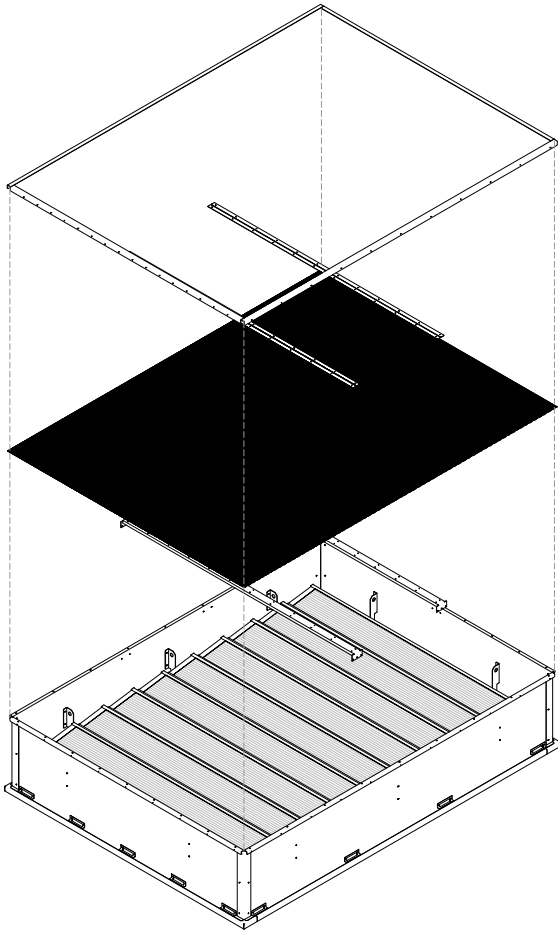

ESQUEMA DE MONTAGEM

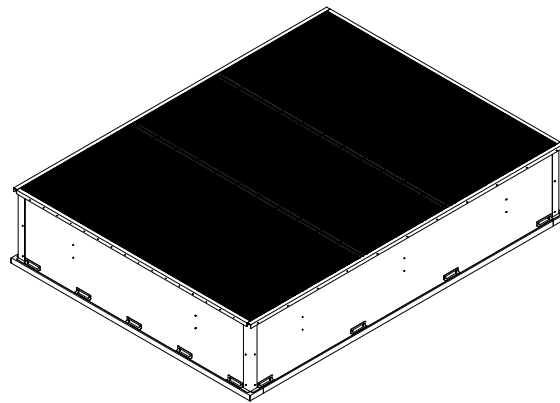

VISTA EM PERSPETIVA

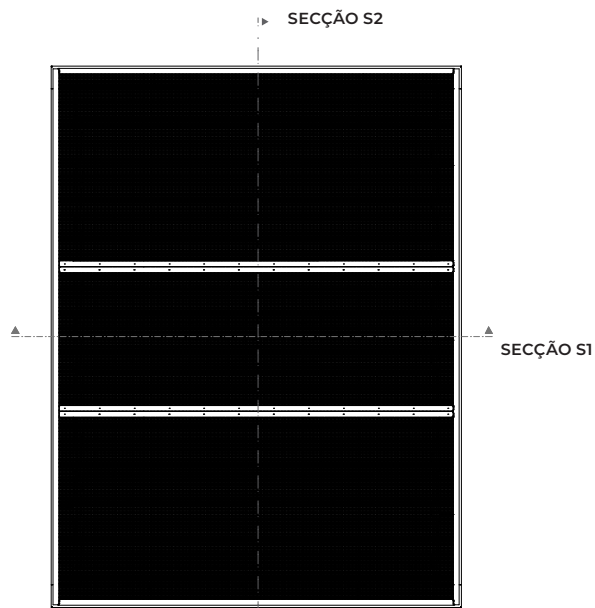

VISTA DE TOPO

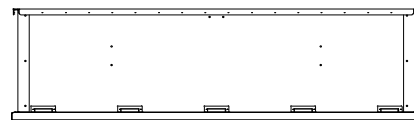

VISTA FRONTAL

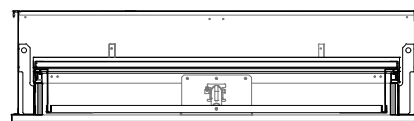

SECÇÃO S1